



The Original
GORILLAGRIP



World's Strongest



**Quick Die Change
Systems**



*Quality, Reliability and Value - Built into an
American Made Product, Backed by a 4-Year Warranty*

Pacesetter Systems

25315 Ave. Stanford
Valencia, CA 91355

Toll Free: 866-EZSETUP (397-3887)
(661)-295-8941

Fax: 661-295-8943

www.pacesettersystems.com



The Original

Heavy Lift Pneumatic Die Lifters



The Original

Hydraulic Die Lifters

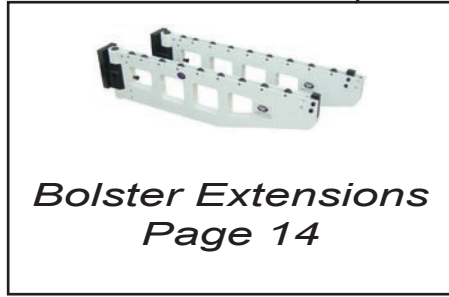
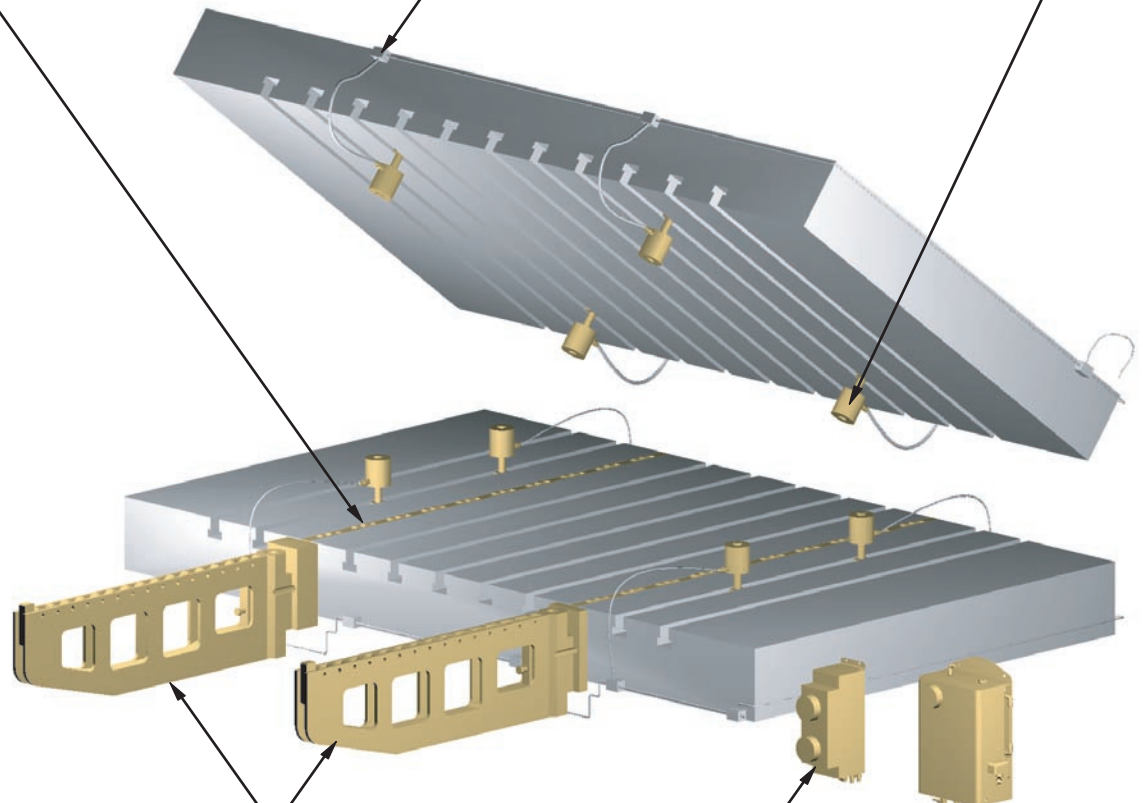

Table of Contents

Pacesetter Systems • Toll Free: 866-EZSETUP • www.pacesettersystems.com

Introduction	Page
Quick Die Change Return on Investment.....	4
Methods of Die Standardization.....	5
Available Clamp Locking Safety Systems.....	6
Selecting Appropriate Clamps and Die Lifters.....	7
Die Lifters/Rollers	
AirGlide™ Pneumatic Die Lifters.....	8
HydraGlide™ Hydraulic Die Lifters.....	9
Spring Powered Cartridges.....	12
Spring Powered Die Lifters.....	13
Die Transfer Equipment	
Die Transfer Rails.....	10
Die Roller Table Tops.....	11
Bolster Extensions.....	14
Power Pallet (Push/Pull Die Loading System).....	19
Die-Align™ (Premium Die Positioner).....	19
Accessories	
Die Standardization Accessories.....	16
Accessories.....	17
Power Supplies & Controllers	
Pneumatic Switch (Air Control Valve).....	18
Air-Driven Hydraulic Power Supply.....	20
Controllers.....	20
Clamps	
GorillaGrip™ Adjustable Hydraulic Rocker Clamps.....	21
GorillaGrip™ Hydraulic Rocker Clamps.....	22
Gorilla Grip™ Hydraulic Cylinder Clamps.....	23
GorillaGrip™ Hydraulic Ledge Clamp.....	24
Mechanical Rocker Clamp.....	25
Diesetter™ Mechanical Clamps.....	26

Return On Investment for a QDC System

Pacesetter Systems • Toll Free: 866-EZSETUP • www.pacesettersystems.com

Much has been written in the past about the benefits of a quick die change system. Speed, safety and labor cost reductions are all significant factors in considering whether a QDC system is right for your shop. However, in today's competitive business environment, the factor shop owners consider most is return on investment or ROI. That is, when will a QDC system pay for itself and begin to pay dividends for their business?

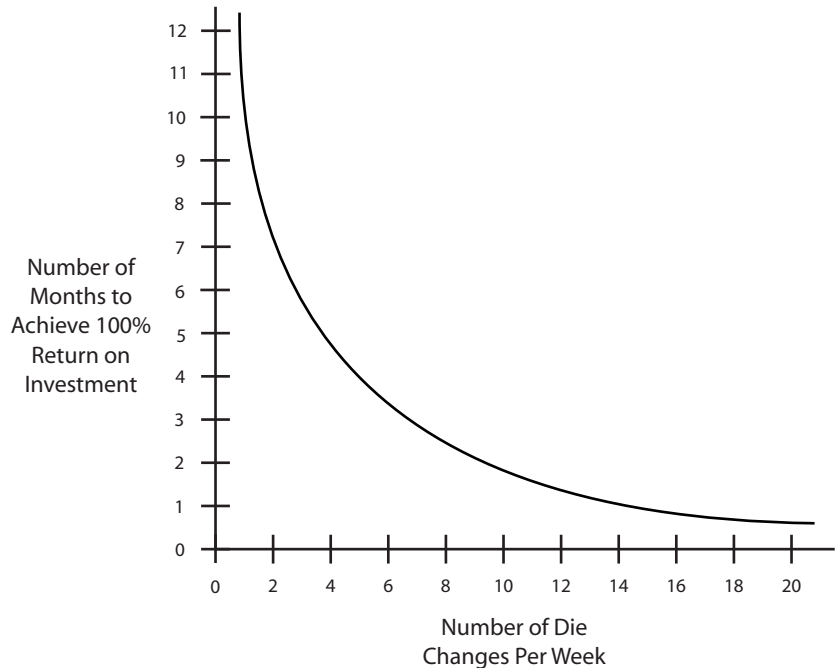

Unfortunately, there is no simple answer to that question, as each business is unique and each will have different results. But one thing is clear, the more often you change dies, the more you need a QDC system and the faster that system will pay for itself.

The graph above illustrates this point. The graph assumes a \$100 savings per die change related to reduced machine down time and fewer labor hours per die change. Most shops save much more than that and these assumptions do not include cost avoidance and ancillary benefits, which further increase the savings, but would require a dissertation from an accountant to explain. Nobody wants to read that!

So what is the bottom line? Based on just two dies changes per week, a QDC system can pay for itself in as little as 6 months and the more die changes you make, the sooner the system begins adding to your bottom line. It's that simple. As you can see, even with these conservative assumptions, the return on investment for a QDC system can be quite impressive.

If you're looking for ways to streamline your operation, a QDC system may be just what you've been looking for. And, if you're looking for the world's strongest QDC system that's 100% Made in USA and backed by an industry-leading warranty, look no further than Pacesetter Systems.

Methods of Die Standardization

Pacesetter Systems • Toll Free: 866-EZSETUP • www.pacesettersystems.com

Proper die standardization is the cornerstone of any QDC system. The goal is to create the same clamping "footprint" on each of your die sets. By standardizing your die sets, you eliminate the need to move or readjust clamps when one die set is removed and another loaded onto the press. The methods of die standardization are outlined below.

Solid Sub-Plates with Fixed Footprint

All die sets are attached to plates of equal dimension

- Provides continuous surface under die set for rolling elements, locating and support
- Provides uniform height of grip ledges
- Allows constant footprint to interface with fixed location clamps
- Eliminates need for T-slots if clamps are in fixed locations

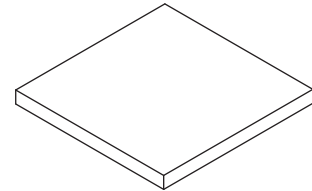

Solid Sub-Plates with Random Footprint

Die sets are attached to sub plates of equal height, but unequal width and length

- Provides continuous surface under die set for rolling elements, locating and support
- Provides uniform height of grip ledges
- Provides best economy for sub-plate to die set size selection

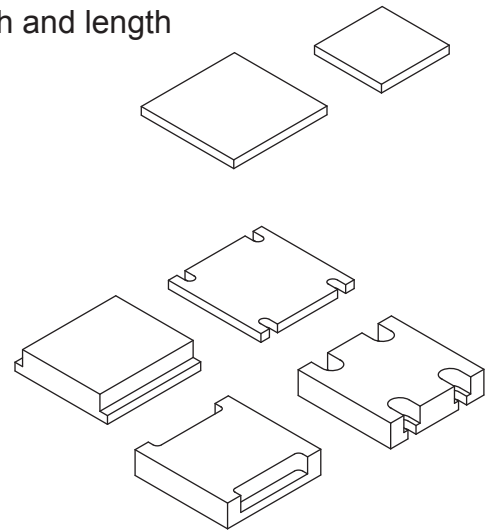

Milled U-slots or Ledges

U-slots or ledges of equal size are milled into the die sets

- Modifications to existing die sets to create common grip
- Achieves die standardization without additional hardware

Easy-Add Flanges from Pacesetter Systems

Our Easy-Add flanges are the quickest, most cost-effective route to die standardization

- Can be bolted or welded onto dies
- Quickest route to complete die standardization
- Provides consistent clamping surface
- Economical alternative to milling die sets
- High-quality steel for reliable clamping

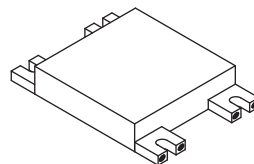

Die with Easy-Add U-Slot Flange

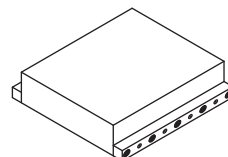

Die with Easy-Add Ledge Flange

Available Clamp Locking Safety Systems

Pacesetter Systems • Toll Free: 866-EZSETUP • www.pacesettersystems.com

Redundant Circuits

A redundant circuit setup uses four or more clamps on the bolster and ram, with two separate hydraulic circuits each powering half of the clamps. The system is configured so that clamps on opposite corners are powered by the same circuit. If hydraulic pressure is lost in circuit #1, the dies will be held in place by the clamps powered by circuit #2.

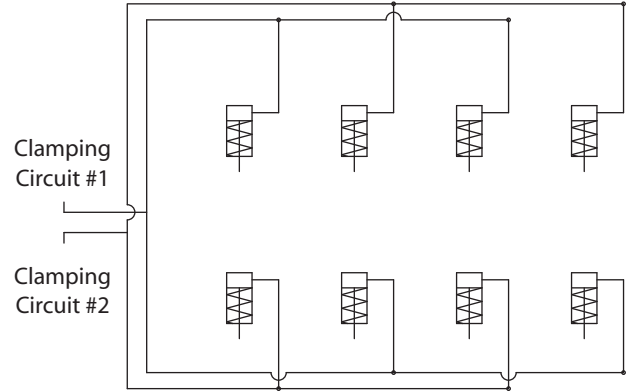

Eight clamp redundant circuit schematic

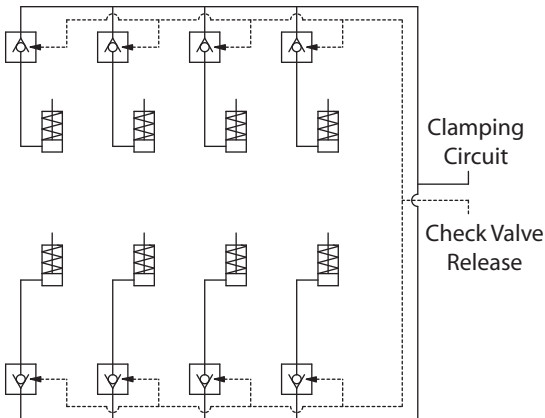

Schematic for clamping system with hydraulic check valves

Hydraulic Check Valves

Our hydraulic clamping systems can be configured with our Model 180 check valve, which prevents pressure loss at the clamps if system pressure is lost. In addition, if pressure is lost at one clamp, the remaining clamps will not be affected. Check valves are pilot operated and can be configured to release automatically when system pressure is turned off or connected to a separate valve to be released manually, for added safety.

Mechanical Locks

Most Pacesetter Systems hydraulic clamps are available with optional mechanical locks. Once pressure is applied to the system, the mechanical lock can be set. When the mechanical lock is set, system pressure can be deliberately turned off and the load will stay securely in place.

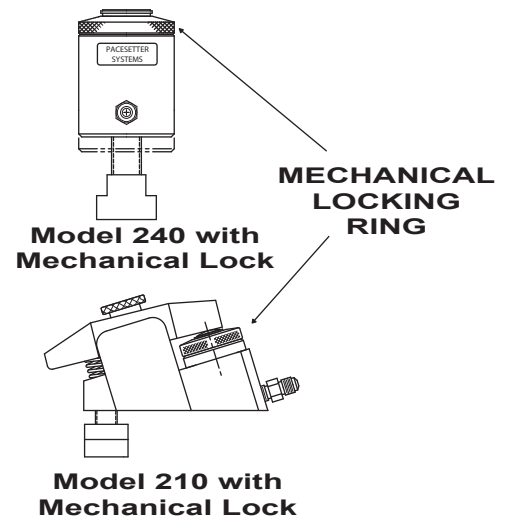

Selecting the Appropriate Clamps and Lifters

Pacesetter Systems • Toll Free: 866-EZSETUP • www.pacesettersystems.com

Clamp Selection*

If your dies have ledge type flanges:

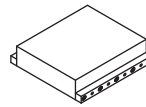

Then use any of the following clamps:



Models
210, 220, 230



Models
351, 352, 354



Model 360



Model 325



Model 71

If your dies have U-slot type flanges:

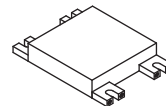

Then use any of the following clamps:



Models
240, 241, 245, 260, 261,
265, 280, 281, 285



Model 70

Die Lifter Selection*

If your bolsters have T-slots:

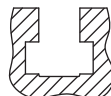

Then use any of the following rails:



Air Glide
Model 515



Hydra Glide
Model 400



Spring Lift
Model 510

If your bolsters have U-slots:

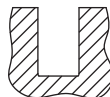

Then use any of the following rails:



AirGlide
Model 516



Hydra Glide
Model 401

*Represents Standard Configurations. Other options are available per customer request.

AirGlide™ Pneumatic Die Lifters

Pacesetter Systems • Toll Free: 866-EZSETUP • www.pacesettersystems.com

Application

Air Glide Heavy Die Lifters are designed to provide ample lifting force in situations where hydraulic lifters are not preferable or available.



Features

AirGlide die lifters feature high-quality o-ring seals and precision ground bearings for the ultimate in die moving efficiency. There are no bladders or air bags to puncture, pinch or deteriorate, making them the most reliable pneumatic die lifters in the industry.

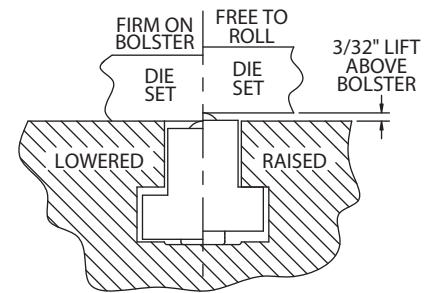

Benefits

- Produces heavy lifting force with standard shop air pressure
- Available with ball or cylindrical bearings
- Installs easily in standard ANSI T-slots or U-slots
- Precision ground bearings for long life and effortless movement
- Available from stock in 6" increments up to 120"
- Custom and metric sizes available for any application per customer request

T-Slot Selection Table

AirGlide™ Rails	Nominal T-slot Size	Ball Bearing Max. Load Lbs./Ft.	Cylindrical Bearing Max. Load Lbs./Ft.
515-5/8" T-slot	5/8"	800	N/A
515-3/4" T-slot	3/4"	800	1,000
515-1" T-slot	1"	1,000	1,000

U-Slot Selection Table

AirGlide™ Rails	Nominal U-slot Size	Ball Bearing Max. Load Lbs./Ft.	Cylindrical Bearing Max. Load Lbs./Ft.
516-1 1/4" U-slot	1 1/4"	800	N/A
516-1 3/8" U-slot	1 3/8"	1,000	1,000

* For Use With: Model 105D Air Control Valve Kit (page 18)

HydraGlide™ Hydraulic Die Lifters

Pacesetter Systems • Toll Free: 866-EZSETUP • www.pacesettersystems.com



Application

For use when maximum lifting power is required. Designed to fit in existing T-slots or U-slots with a wide range of carrying capacities available

Features

Available with cylindrical or ball bearings. Precision ground bearings for long life and effortless die movement. Available in standard and custom sizes.

Benefits

- Available with ball or cylindrical bearings
- Produces maximum lifting force for the heaviest loads
- Installs easily in standard ANSI T-slots or U-slots
- Precision ground bearings for long life and effortless movement
- Available in standard and custom lengths
- Custom and metric sizes available for any application per customer request

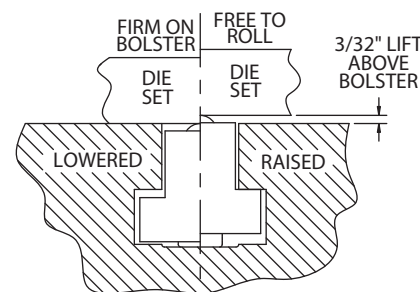

T-Slot Selection Table

HydraGlide™ Model Number	Nominal T-slot Size	Ball Bearing Max. Load Lbs./Ft.	Cylindrical Bearing Max. Load Lbs./Ft.
400-5/8" T-slot	5/8"	800	N/A
400-3/4" T-slot	3/4"	800	2,000
400-1" T-slot	1"	1,000	2,000
400-1" HD	1"	1,200	2,600
400-1 1/8" T-slot	1 1/8"	1,200	2,600
400-1 1/4" T-slot	1 1/4"	1,200	2,600

U-Slot Selection Table

HydraGlide™ Model Number	Nominal U-slot Size	Ball Bearing Max. Load Lbs./Ft.	Cylindrical Bearing Max. Load Lbs./Ft.
401-3/4" U-slot	3/4"	800	2,000
401-1" U-slot	1"	1,000	2,600
401-1 3/4" U-slot	1 3/4"	1,400	2,800
401-2" U-slot	2"	1,400	2,800

* For Use With: Power Supply (page 20) and Installation Kit.

Transfer Rails

Pacesetter Systems • Toll Free: 866-EZSETUP • www.pacesettersystems.com

Application

Provides quick and easy movement of dies from the press to the storage or staging area. Excellent alternative to expensive die carts.



Features

Available with cylindrical or ball bearings. Both styles can be ordered with high-density bearing surface for maximum load carrying capacity.

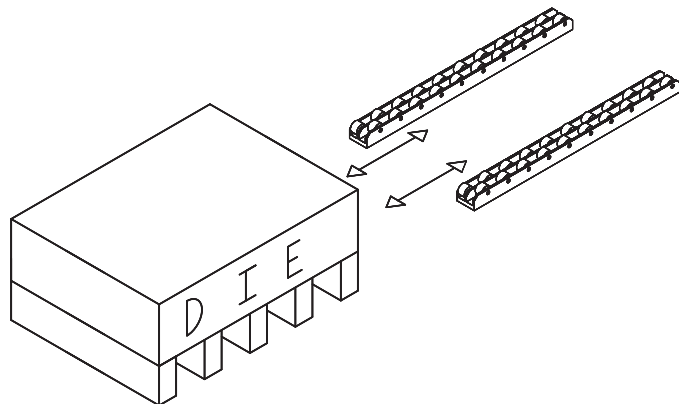

Benefits

- Able to support the heaviest dies
- Cylindrical or ball bearings
- Installs easily on storage racks and transfer carts
- Precision ground bearings for long life and effortless movement
- Custom sizes available for any application per customer request

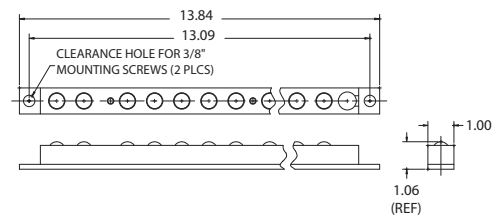

Model 530 Spherical Bearing

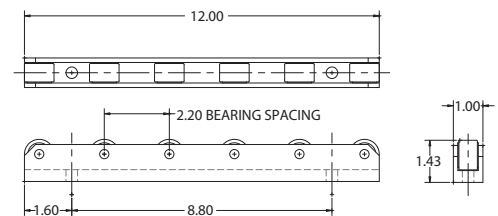

Model 531 Cylindrical Bearing

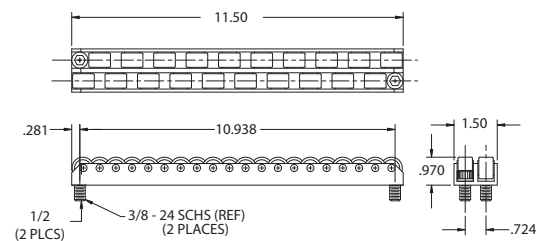

Model 532 High-Density Cylindrical Bearing

Model No.	Transfer Rail Type	Max. Load lbs./ft.
530	Spherical Bearing	1,200
533	High Density Spherical Bearing	2,400
531	Cylindrical Bearing	2,000
532	High-Density Cylindrical Bearing	3,000

Die Roller Table Tops

Pacesetter Systems • Toll Free: 866-EZSETUP • www.pacesettersystems.com

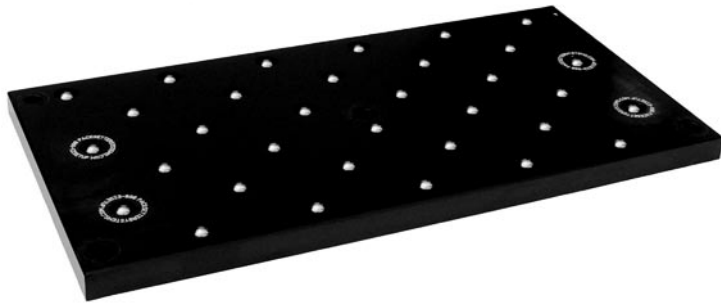

Application

Designed for easy staging of dies during die changeover. Economical alternative to expensive die carts. Can handle die weights up to 1,800 lbs. per square foot.

Features

High-quality, precision ground chrome ball bearings for easy die movement in any direction. Heavy-duty rollers for a lifetime of reliability.

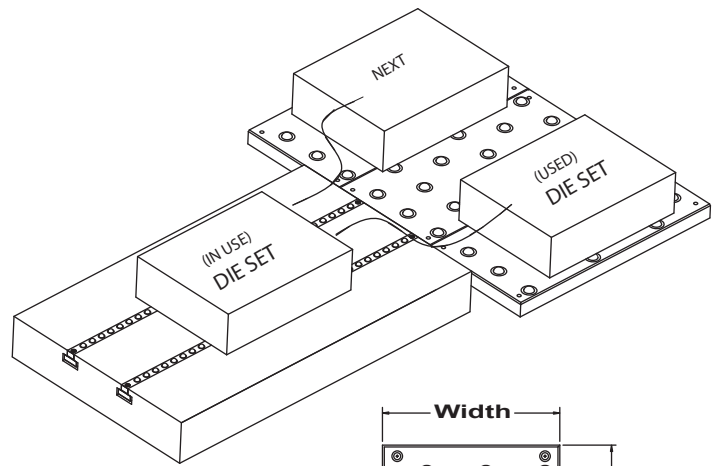

Benefits

- Easy pre and post staging of dies
- Economical alternative to expensive die carts
- Precision ground bearings for effortless die movement
- Die weights up to 1,800 lbs. per square foot

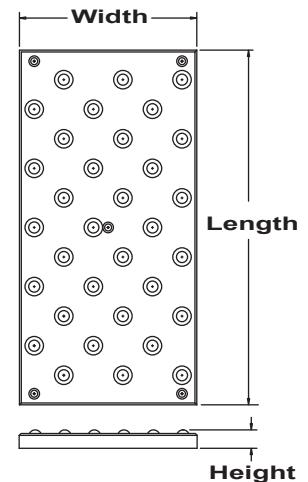

Model No.	Length	Width	Height	Capacity Lbs./Sq. Ft.
520-2	24"	2"	1.25"	1,800
520-8	24"	8"	1.25"	1,800
520-12	24"	12"	1.25"	1,800
520-36	24"	36"	1.25"	1,800
520-36X36	36"	36"	1.25"	1,800

Insertable Spring Lift Cartridges

Pacesetter Systems • Toll Free: 866-EZSETUP • www.pacesettersystems.com

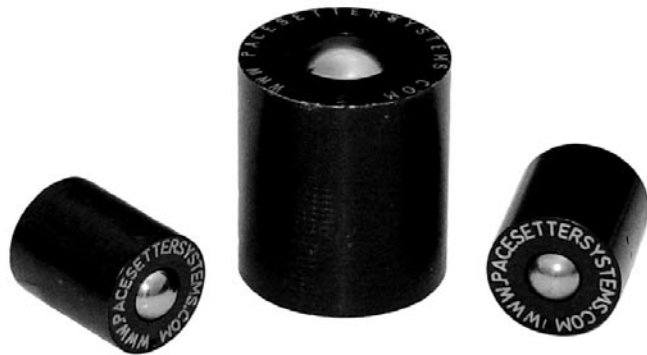

Model 505

Application

For use when T-slots are not available. Cost-effective alternative to expensive T-slot machining. Excellent for use where hydraulic systems are not available or not desirable.

Features

Precision ground chrome bearings for effortless die movement in any direction. Easy retrofit to bolsters, with only simple drilling tools required. Available in four sizes to meet any die moving application. Easy installation and removal, without special tools.

Benefits

- Precision-ground bearings for ultra smooth rolling
- Extra-large bearings for maximum load capacity
- Perfect for applications where T-slots are not available
- Available in 3/4", 1", 1 3/16" and 1 5/8" sizes
- Permits die movement in all directions
- Installs easily in standard-size drilled holes - no special flat-bottom required
- Install and remove without special tools

Spring Lift Cartridges 505 Series	Maximum Load (Lbs./Each Roller)	Hole Dia. (-.000"/+.010")	Hole Depth (±.005")	Alternate Flat-Bottom Hole Depth (±.005")
505-3/4"	45	.750"	0.990"	1.010"
505-1"	75	1.00"	1.110"	1.130"
505-1 3/16"	120	1.187"	1.355"	1.375"
505-1 5/8"	210	1.625"	1.750"	1.770"

Spring Lift Rails

Pacesetter Systems • Toll Free: 866-EZSETUP • www.pacesettersystems.com

Application

Excellent for use where hydraulic systems are not available or not desirable. Designed for easy installation and hassle-free performance.

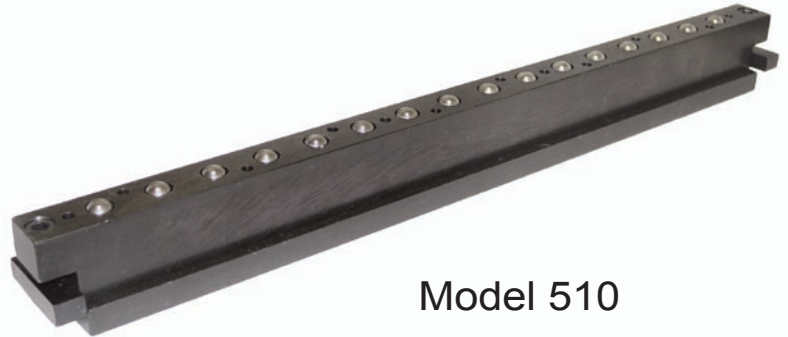

Model 510

Features

Precision ground chrome steel bearings for effortless die movement in any direction. Available in three sizes for installation in standard T-slots or U-slots. Easy installation and removal, without special tools.

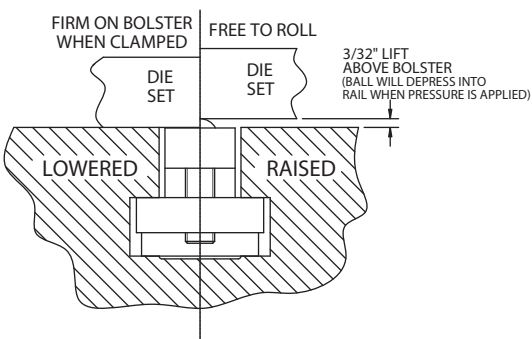

Benefits

- Installs in minutes
- Precision-ground bearings for ultra smooth rolling
- Heavy duty springs for maximum load capacity
- Perfect for applications where hydraulic systems are not available or desirable
- Available for 5/8", 3/4" and 1" T-slots or U-slots
- Permits die movement in all directions
- Available in lengths from 6" to 96"

Spring Lift Rails 510 Series	Nominal T-slot Size	Max. Load lbs./ft.
10", 12" & 18"	5/8"	550
10", 12" & 18"	3/4"	550
12" & 18"	1"	750

Bolster Extensions

Pacesetter Systems • Toll Free: 866-EZSETUP • www.pacesettersystems.com



Application

Easily load and unload dies that do not have risers. Our 48" Bolster Extensions are the strongest in the industry, handling loads up to 16,000 lbs., without the need for support legs.

Benefits

- Installs easily between or in-line with T-slots
- Precision ground bearings for easy movement
- Share lift-off models between presses
- Folding models fold flush against press
- Custom lengths available on request
- Designed with 3/32" roller lift to align with bolster die lifters

Features

Available in lift-off or folding models. High-quality precision ground bearings for reliability and easy die movement. Available from stock in a wide variety of sizes, with custom sizes available on request.

Locate holes for your bolster extensions quickly and accurately with our Precision Drill Fixture (page 18).

Load Lbs./Pair.	Die Resting Length	Lift Off Model No.	Length	Height	Minimum Bolster Thickness	Folding Model No.	Length	Height	Minimum Bolster Thickness
6,000	15"	549L-15	15"	6"	4.5"	---	---	---	---
	19"	549L-19	19"	6"	4.5"	549F-19	19"	6"	4.0"
	23"	549L-23	23"	6"	4.5"	549F-23	23"	6"	4.0"
	27"	549L-27	27"	8"	6.5"	549F-27	27"	6"	4.0"
	31"	549L-31	31"	8"	6.5"	549F-31	31"	8"	4.0"
	35"	---	---	---	---	549F-35	35"	8"	4.5"
	36"	---	---	---	---	549F-36	36"	10"	6.0"
	37"	549L-37	37"	10"	7.8"	---	---	---	---
	42"	---	---	---	---	549F-42	42"	10"	6.0"
	43"	549L-43	43"	10"	7.8"	---	---	---	---
10,000	15"	550L-15	15"	6"	4.5"	---	---	---	---
	19"	550L-19	19"	6"	4.5"	550F-19	19"	6"	4.0"
	23"	550L-23	23"	6"	4.5"	550F-23	23"	6"	4.0"
	27"	550L-27	27"	8"	6.5"	550F-27	27"	6"	4.0"
	31"	550L-31	31"	8"	6.5"	550F-31	31"	8"	4.5"
	35"	---	---	---	---	550F-35	35"	8"	4.5"
	36"	---	---	---	---	550F-36	36"	10"	6.0"
	37"	550L-37	37"	10"	7.8"	---	---	---	---
	42"	N/A	N/A	N/A	N/A	550F-42	42"	10"	6.0"
	43"	550L-43	43"	10"	7.8"	---	---	---	---
16,000	48"	550L-48	48"	10"	7.8"	550F-48	48"	10"	6.0"
	31"	552L-31	31"	10"	7.8"	---	---	---	---
	36"	---	---	---	---	552F-36	36"	10"	6.0"
	37"	552L-37	37"	10"	7.8"	---	---	---	---
	42"	---	---	---	---	552F-42	42"	10"	6.0"
43"	552L-43	43"	10"	7.8"	---	---	---	---	
48"	552L48	48"	10"	7.8"	552F-48	48"	10"	6.0"	

Quotation Request

Fax to: 661-295-8943

General Information

Company Name: _____

Contact: _____ Title: _____

Address: _____

Phone: _____ Ext: _____ Fax: _____ Email: _____

Press Information

Manufacturer and Model: _____

Press Type: C-Frame Straight Side Tonnage: _____

Bolster Dimensions: _____ (Width L-R) x _____ (Length F-B) x _____ Height (Thickness)

T-Slots: L-R F-B None

T-Slot Dimensions: A _____ B _____ C _____ D _____ E _____

Ram Dimensions: _____ (Width L-R) x _____ (Length F-B) x _____ Height (Thickness)

T-Slots: L-R F-B None

T-Slot Dimensions: A _____ B _____ C _____ D _____ E _____

Maximum Stripping Force: _____

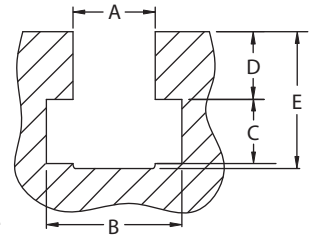

Die Information

Maximum Total Weight: _____ Lbs. Upper: _____ Lbs. Lower _____ Lbs.

Dimensions: Maximum _____ L-R x _____ F-B Minimum _____ L-R x _____ F-B

Clamping Ledge Shoe Height: Bolster _____ Ram _____

Are Dies Slotted for Clamps? Yes No

Number of bolts currently used to clamp dies: Bolster _____ Ram _____

Dies Loaded From: Left Right Front Back

Dies Unloaded From: Left Right Front Back

Die Transfer & Alignment Equipment

Power Pallet: Yes No

Model 536 (6,000 lbs capacity): _____ Model 535 (3,000 lbs capacity): _____

Die-Align (Die Positioner): Yes No Number of Sets? _____

Clamping Information

Type of Clamps Preferred: **Select Type of Lock Preferred:**

Hydraulic Rocker Clamps Manual Lock Hyd. Check Valve Fully Hydraulic

Adj. Hyd. Rocker Clamps Manual Lock Hyd. Check Valve Fully Hydraulic

Hyd. Ledge Clamps Manual Lock Hyd. Check Valve Fully Hydraulic

Hydraulic Cylinder Clamps Manual Lock Hyd. Check Valve Fully Hydraulic

Mechanical Clamps

Die Lifter Information

Type of Die Lifters Preferred: **Select Type of Bearings Preferred:**

Hydraulic Lift Ball Type (Spherical) Cylinder Type

Pneumatic Lift Ball Type (Spherical) Cylinder Type

Spring Lift

Bolster Extensions

Lift-off Type Folding Type Length _____

Hydraulic Controls

Manual 2-Position Valve Electric Switch

Pacesetter Systems

Toll Free: 866-EZSETUP (397-3887)

www.pacesettersystems.com

Accessories

Pacesetter Systems • Toll Free: 866-EZSETUP • www.pacesettersystems.com

Easy-Add U-Flange

Model 696

- For use with Diesetter mechanical clamps or hydraulic cylinder clamps
- Can be bolted or welded onto dies
- Precision machined high strength steel

Easy-Add Ledge Flange

Model 602

- For use with Diesetter mechanical clamps or hydraulic rocker clamps
- Can be bolted or welded onto dies
- Custom lengths for any size dies

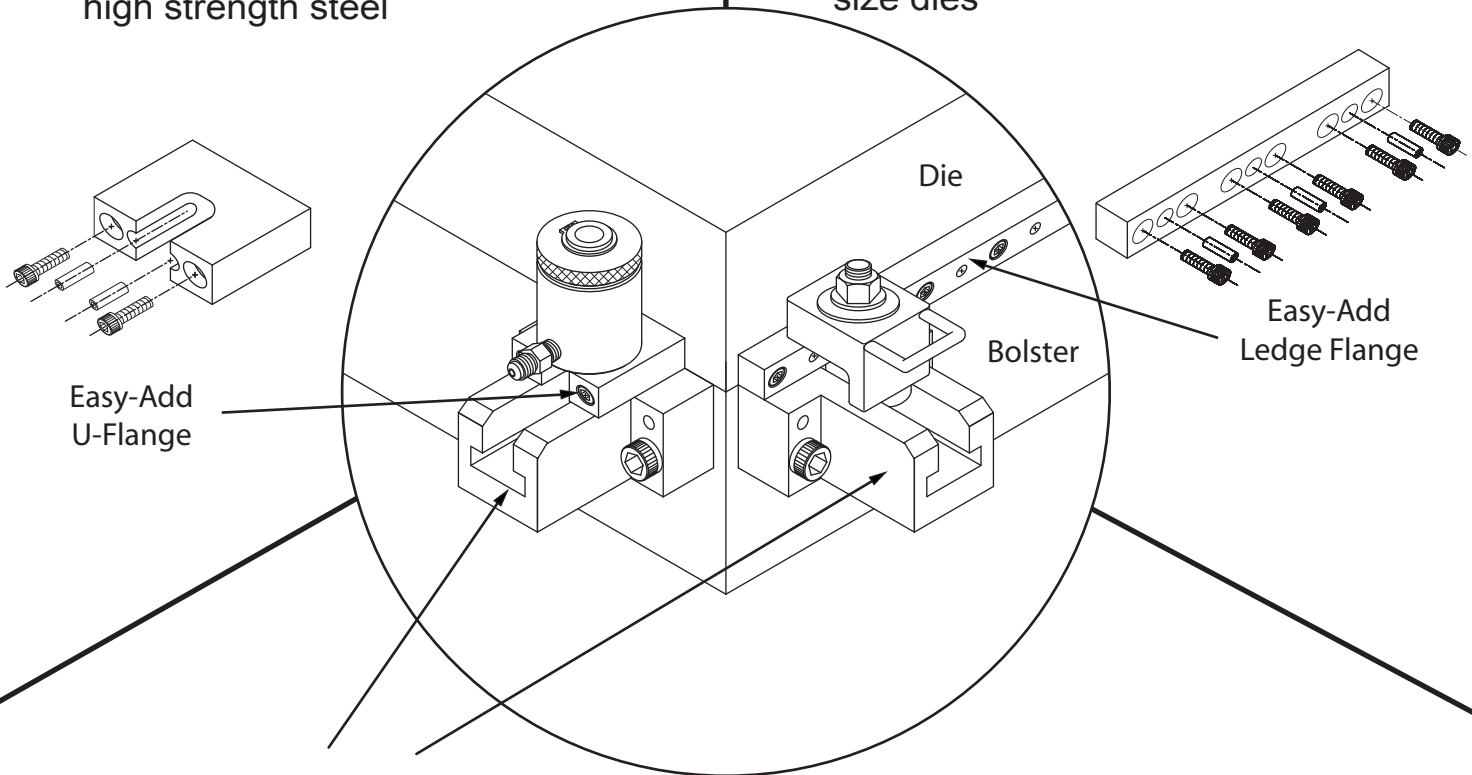

T-slot Extenders

Model 601

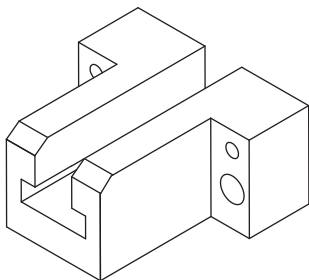

- Increases usable bolster and ram surface
- Clamps can be used beyond bolster or ram edge
- Allows bolster or ram mounted clamps to be moved out of the way during die change



Hydraulic Pump Model P71

Air/oil hydraulic pump with 6,000 psi. standard operating pressure.



Hose Making Kit Model 620

Everything you need to make custom length high pressure hydraulic hoses. Crimping tool is powered by the same Pacesetter Systems power supply operating clamps and lifters.



4-way Valve P/N 10158

Directional fluid control valve to control fluid flow to hydraulic clamps and lifters. Metal-to-metal seals with zero internal leakage at 6,000 psi.

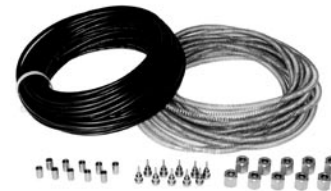

Hose Making Refill Kit Model K620

Everything you need to restock your hose making kit. Includes hose and hardware.



Pressure Switch Model 170

Monitors hydraulic system pressure or individual circuit pressure and stops press if pressure drops below prescribed levels.



Pre-made hydraulic hoses Model 625, or 626-(Large Size)

Available in a wide variety of sizes from stock or custom made to your specifications.



Hydraulic Hose Quick Disconnect Model 649

Allows you to quickly disconnect the hydraulic lines once your clamps are clamped and mechanically locked to prevent them from being inadvertently damaged by the press.



Junction Blocks P/N PS-102

Route your hydraulic lines any way you please with our versatile junction blocks. More than 30 configurations available.

Contact us for a complete list.

Accessories

Pacesetter Systems • Toll Free: 866-EZSETUP • www.pacesettersystems.com

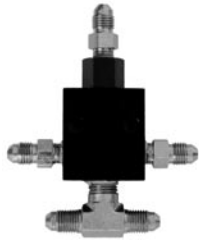

**Check Valve
Model 180**

Pilot operated safety valve prevents clamps from releasing if system pressure is lost.



**Pneumatic Switch
Model 105-D**

Controls air pressure to AirGlide Heavy Lift pneumatic die lifters. Raises and lowers lifters with the flick of a switch.



**Hydraulic Oil
Model 630**

Premium grade hydraulic oil for HydraGlide rails and Gorilla Grip clamps.



**Lift-off Bolster Extension Brackets
Model 603**

Mount on side of bolster to attach lift-off type bolster extensions.



**Drilling and Tapping Fixture
Model T-252**

For precisely locating and tapping bolster extension mounting holes. Made from high quality steel with heat-treated steel bushings.



**Clamp Parking Brackets
P/N 4041-1**

Hang clamps out of the way during die change on our sturdy parking brackets.



T-Nuts

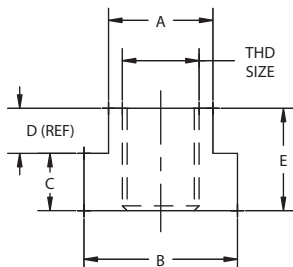

Nominal T-Bolt Size	Thread Size	Part Number	"A"	"B"	"C"	"D"	"E"
5/8"	5/8"-11	6655	.64	1.13	.36	.39	.75
3/4"	3/4"-10	6656	.77	1.25	.50	.25	.75
1"	3/4"-10	6658-2	1.02	1.75	.58	.42	1.0
1"	7/8"-9	6657	1.02	1.75	.58	.42	1.0
1"	1"-8	6658	1.02	1.75	.58	.42	1.0

High surface area T-nuts provide maximum holding power. Available with tapped-through or non-tapped-through threads.

Power Pallet

Push/Pull Die Loading System

Pacesetter Systems • Toll Free: 866-EZSETUP • www.pacesettersystems.com

Application

The Power Pallet is the ultimate efficient die loading system that eliminates the need for die carts and increases safety more than ever before. It's designed to attach to any standard forklift.

Features

Powered by a rechargeable battery that's good for 12 die changes, the Power Pallet can load/unload dies with just the push of a button, and at various speeds. It features rails that easily latch on to pins pre-installed on dies, and then can either push or pull with the turn of a built-in gear switcher. Also comes with brackets that mount on the front of bolster for the purpose of easydocking action with the pallet.

Includes our world-famous pneumatic die lifters for smooth die gliding action.

Benefits

- Relatively small size makes it easy to store, no more need for die carts
- Able to load/unload up to 6,000 lbs load capacity in die weight
- Simple push/pull design reduces the risk of injury and strain on your workforce

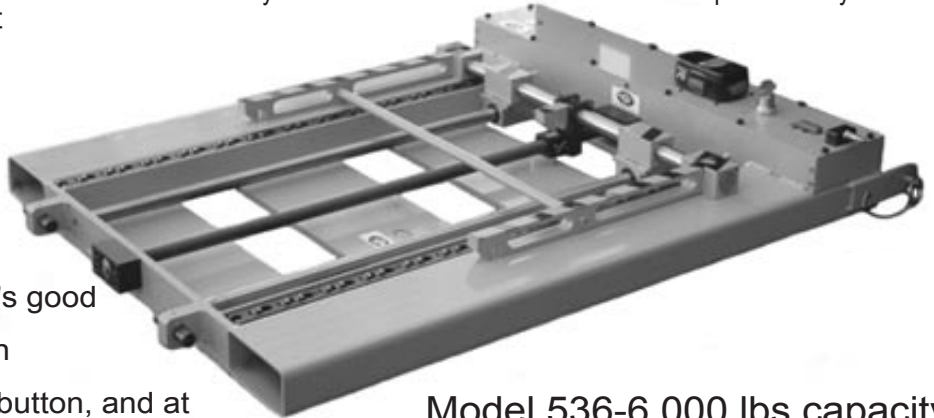

Model 536-6,000 lbs capacity

Model 535-3,000 lbs capacity

**Call for a free
demonstrational DVD**

Power Pallet

Die-Align™

**Totally eliminates manual alignment
when used with the Power Pallet**

This innovative tool makes it easy to accurately locate and center any die on your press. The V-Block mounts on the back of the die shoe and guides it left to right, and front to back around a pin (1-inch diameter) that's installed in the bolster. The stop block rests on the other side of the die and helps square it evenly on the press. Die-Align is designed to align a die of any size.

Model 631

V-Block



Stop-Block

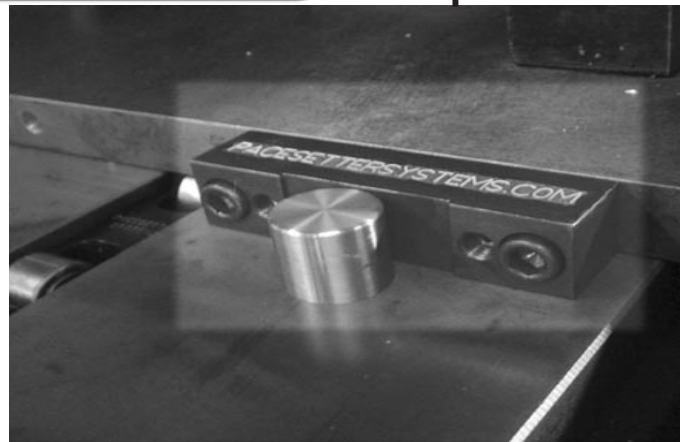

Power Supplies and Controllers

Pacesetter Systems • Toll Free: 866-EZSETUP • www.pacesettersystems.com



Application

Air-driven hydraulic power supply for controlling and monitoring hydraulic circuits. Can be used with external controllers to operate a maximum of five circuits. Operates HydraGlide hydraulic die lifters and GorillaGrip hydraulic clamps.

Features

Powered by normal shop air pressure (80-150 psi.), with no electrical requirements. Hydraulic pressure is controlled by an adjustable air regulator. System pressure is displayed by a full-range hydraulic pressure gauge. Hydraulic reservoir gage to monitor hydraulic fluid levels.

Benefits

- Contains no electrical components
- System pressure displayed by full-range hydraulic pressure gauge
- Hydraulic oil reservoir gage standard on all models
- Powered by normal shop air pressure

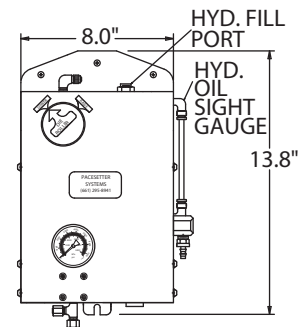

Model 110 Power Supply
In-line Controller



Two-Circuit Manual Controller

Control additional hydraulic circuits powered by a single power supply using our two-circuit manual controller. Up to two manual controllers can be added per power supply.



Electronic Two-Circuit Key Switch Controller

For the ultimate in safety and security. Our two-circuit key switch controller prevents accidental or unauthorized switching of hydraulic circuits.

Manual Controller Model Number	Electronic Controller Model Number	Circuits	Controllers Required
110	E-110	1	None
120	E-120	2	1
130	E-130	3	1
140	E-140	4	2
150	E-150	5	2

Gorilla Grip™ Adjustable Hydraulic Rocker Clamps

Pacesetter Systems • Toll Free: 866-EZSETUP • www.pacesettersystems.com

Application

This extremely versatile clamp is designed for use with die ledges of inconsistent or varying thickness. Gorilla Grip adjustable clamps can be moved around the bolster easily, making them the ideal solution for shops using different sized dies on the same press.

Features

Gorilla Grip adjustable rocker clamps are hydraulically assisted, allowing you to lock the load down tight. Once locked down, they will continue to grip with maximum force, even if the hydraulic system is disconnected.



Benefits

- Available in three sizes
- Up to 15,000 lbs. clamping force
- Precision built for extreme reliability
- Hydraulic line can be removed after clamping
- Wide gripping range for ultimate versatility



Use with Power Supply (page 20) and Model 170 Pressure Switch (page 17).

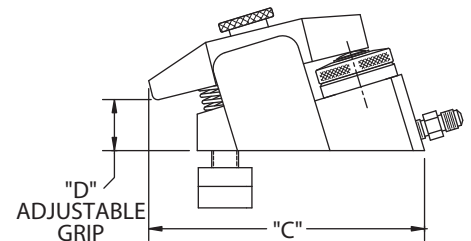
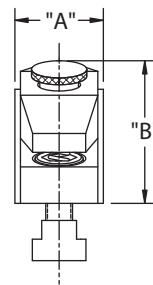

Model No.	Clamping Force @ 6,000 psi	Width "A"	Height "B"	Length "C"	Adjustable Grip "D"
210	4,000 lbs.	2.00"	3.34"	6.4"	0.75"-1.75"
220	10,000 lbs.	2.50"	5.00"	8.84"	0.75"-2.25"
230	15,000 lbs.	3.00"	6.10"	11.14"	1.00"-3.00"

Gorilla Grip™ Hydraulic Rocker Clamps

Pacesetter Systems • Toll Free: 866-EZSETUP • www.pacesettersystems.com



Application

Used for clamping dies with a uniform-height clamping ledge. The optimum configuration for applications requiring strong clamping force from a low-profile clamp. Excellent for shops with standardized ledge flange die sets.

Features

Available in three sizes with clamping force up to 20,000 lbs. Precision built for extreme reliability. Easily move clamps around bolster to accommodate dies of varying sizes.

Benefits

- Available in three sizes
- Up to 20,000 lbs. clamping force
- Precision built for extreme reliability
- Economical low-profile clamping solution
- Accommodates any die shoe thickness

Use with Power Supply (page 20) and Model 170 Pressure Switch (page 17).

Die Set Compatibility

Consistent Thickness Grip Ledge

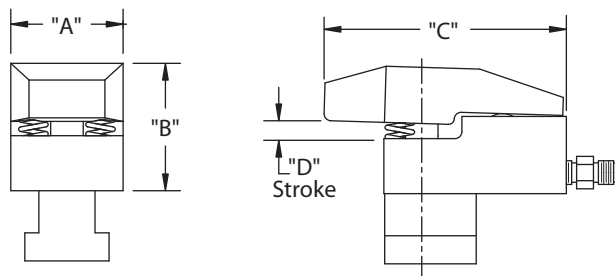
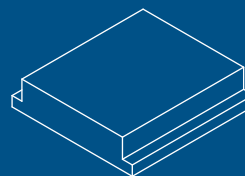

Model No.	Clamping Force @ 6,000 psi	Width "A"	Height "B"	Length "C"	Stroke "D"
351	5,000 lbs.	2.00"	2.27"	4.4"	0.75"-1.25"
352	10,000 lbs.	3.00"	2.27"	4.4"	0.75"-1.25"
354	20,000 lbs.	4.79"	2.87"	5.6"	1.00"-1.50"

Gorilla Grip™ Hydraulic Cylinder Clamps

Pacesetter Systems • Toll Free: 866-EZSETUP • www.pacesettersystems.com



Application

For use with slot-type die shoes with consistent height. Provides high clamping force with minimum space requirements.

Features

Economical and versatile clamping system, with T-nut shaft or threaded shaft for easy installation. Available in full hydraulic and hydraulic assisted models.

Benefits

- Up to 22,000 lbs. clamping force
- Precision built for extreme reliability
- Optional redundant hydraulic circuits for extra safety
- Available with or without mechanical safety locks

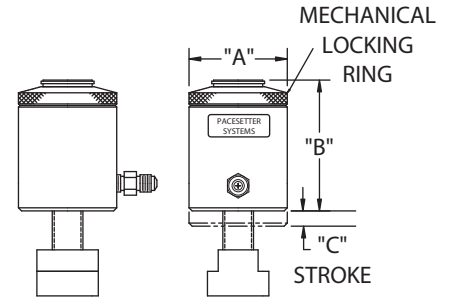

Models
240/260/280

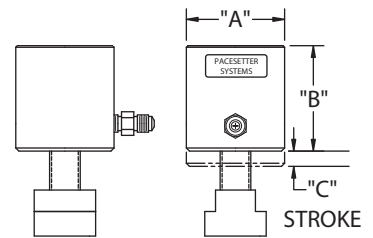

Models
241/261/281

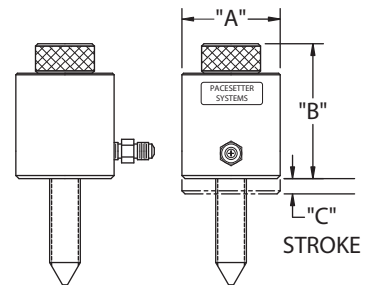

Models
245/265/285

Clamping Force @ 6,000 PSI	Model No.	Installation	Mechanical Lock	Diameter "A"	Height "B"	Stroke "C"
9,000 lbs.	240	T-Nut	Yes	2.00"	2.62"	0.25"
	241	T-Nut	No	2.00"	2.00"	0.25"
	245	Threaded Shaft	No	2.00"	2.85"	0.25"
12,000 lbs.	260	T-Nut	Yes	2.50"	2.73"	0.31"
	261	T-Nut	No	2.50"	2.06"	0.31"
	265	Threaded Shaft	No	2.50"	2.96"	0.31"
22,000 lbs.	280	T-Nut	Yes	3.00"	3.81"	0.38"
	281	T-Nut	No	3.00"	2.88"	0.38"
	285	Threaded Shaft	No	3.00"	4.04"	0.38"

Hydraulic Ledge Clamps

Pacesetter Systems • Toll Free: 866-EZSETUP • www.pacesettersystems.com



Model 360



Application

For applications requiring maximum clamping force in low-profile unit. Optimum for clamping slide-in type dies with uniform clamping ledges. Mounts permanently to the bolster or ram, or in T-slots for use as a movable clamp.

Features

Heavy-duty load holding capacity with up to 40,000 lbs. of clamping force. Precision built for extreme reliability. Complete hands-free operation with minimal die standardization required. Uses check valve or redundant circuits for safety.

Benefits

- Up to 40,000 lbs. clamping force
- Low profile design
- Precision built for extreme reliability
- Complete "hands-free" operation
- Permanent or movable mounting options

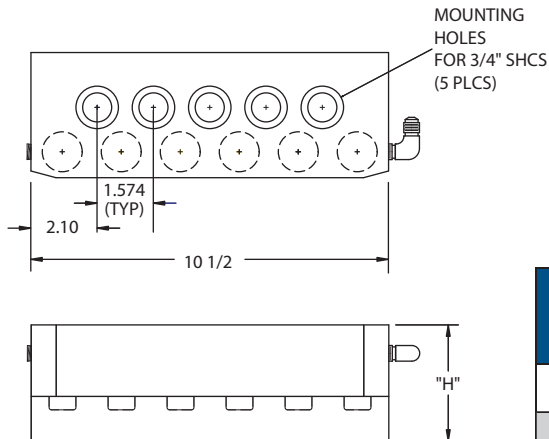

Die Set Compatibility

Consistent Thickness Grip

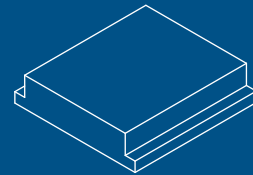

Use with Power Supply (page 20) and Model 170 Pressure Switch (page 17).

Part Number	Grip (min/max)	Height (H)
10452-1.25	1.00/1.25	3.38
10452-1.50	1.25/1.50	3.63
10452-1.75	1.50/1.75	3.88
10452-2.00	1.75/2.00	4.13

Mechanical 1/4 Turn Rocker Clamps

Pacesetter Systems • Toll Free: 866-EZSETUP •

Application

Use when a variety of gripping heights are needed from a mechanical clamp. Excellent alternative when mechanical clamping is preferred.

Features

Accommodates a wide variety of ledge flange thickness. Clamps quickly and easily. Precision built for a lifetime of reliable, hassle-free operation.



4,000 lbs clamping force

Benefits

- Quick and easy clamping
- Broad range of grip height
- Fits in standard ANSI T-slots
- Precision built for extreme reliability
- Economical alternative to hydraulic systems

Die Set Compatibility

Variable Thickness Grip

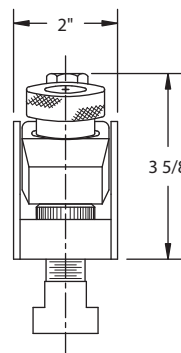
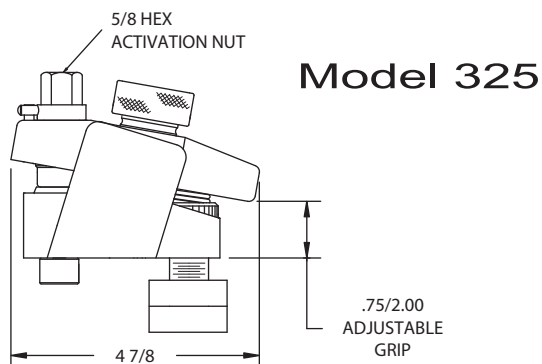
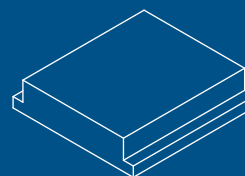

Diesetter™

Mechanical Clamps

Pacesetter Systems • Toll Free: 866-EZSETUP • www.pacesettersystems.com

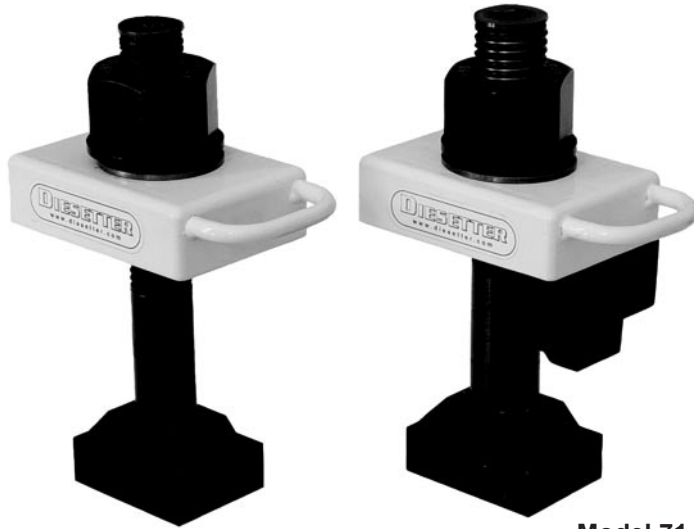

Model 70

Model 71

Two styles available for either U-flange or ledge-type dies.

Benefits

- 1/8-turn clamping action
- Automatically positioned clamp arms for quick alignment with die set
- Precision-machined clamp arm surfaces provide increased surface contact for superior holding
- Up to 44,000 lb. load capacity
- Minimal die standardization
- Ergonomically designed handle for ease of use

Application

For applications where hydraulic clamps are not preferable or available. Can be used with either U-flange or ledge-type flange die sets. Available in several sizes and configurations to handle a wide variety of die sizes.

Features

Exclusive torque-reducing anti-friction thrust bearing, with 1/8 turn clamping action. Precision-machined clamp arm surfaces for superior holding. Ergonomically designed handle for ease of use.

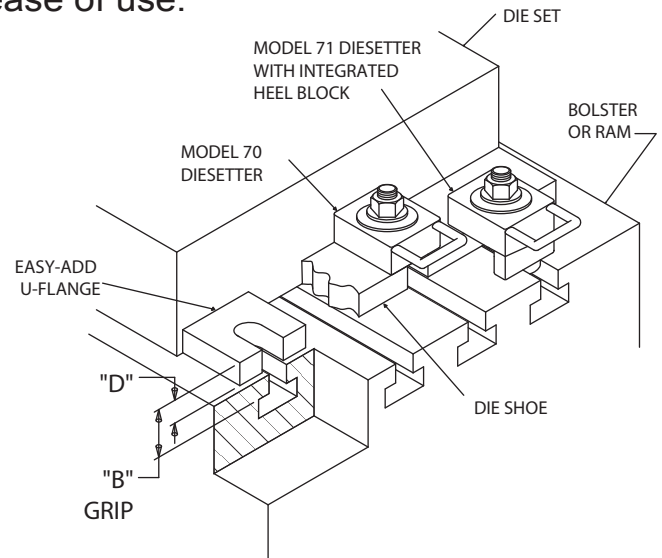

Ordering Information

Step 1: Select Model Number - Model 70 without heel or Model 71 with heel

Step 2: Specify T-Slot Size - 5/8", 3/4" or 1"

Step 3: Select T-Slot Bolt Length - Use column B of the Load and Dimensional Data chart on the following page and identify your desired min./max. total grip height. Total grip height "B" is the T-slot neck height plus the die flange thickness "D". Read across to column "A" and select T-slot bolt length.

Step 4: Select Load Capacity - Identify the load capacity desired for your application and select the color code associated with an equal or higher load capacity.

Step 5: For Model 71 Only, Specify Die Grip Height - Add exact die flange thickness to P/N, after color code

Example 1: Model 70-3/4-6"-Gold = Diesetter Clamp (no heel) for 3/4" T-slot, with a 6" T-bolt and load capacity of 15 tons (30,000 lbs.)

Example 2: Model 71-3/4-6"-Gold-1.500 = Diesetter Clamp (with heel) for 3/4" T-slot and die grip thickness of 1.5", with a 6" T-bolt and load capacity of 9 tons (18,000 lbs.)

Diesetter™

Mechanical Clamps

Pacesetter Systems • Toll Free: 866-EZSETUP • www.pacesettersystems.com

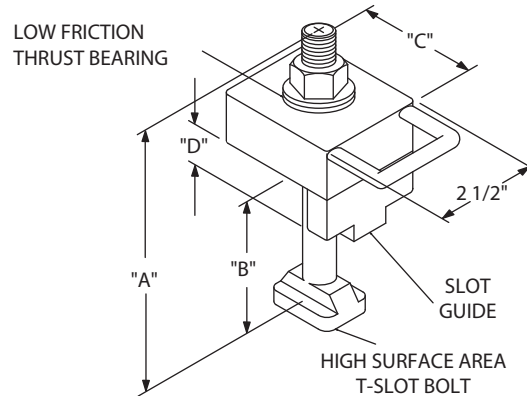
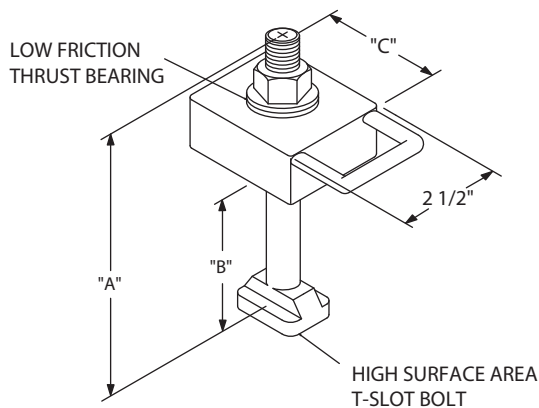

Load and Dimensional Data

T-Slot Bolt Size	Load Capacity		"A" T-Slot Bolt Length	"B" Grip Length – Total including T-Slot Throat Height		Hex Nut Size (Thread Size)	Torque Ft.-Lbs.	"C" Clamp Arm Length	"D" (Mod 71 only) Height of Die Clamping Ledge
	Series	Load		Min. Grip	Max. Grip				
5/8	5/8 Gold	10 Tons *	3 1/2	.31	1.9	1 1/16 Hex (5/8-11 Thd.)	80	2 1/2	Specified by User
			4	.31	2.4				
			5	.31	3.4				
3/4	3/4 Blue	6 1/2 Tons *	4	0.5	1.75	1 1/4 Hex (3/4-10 Thd.)	125	3 1/2	Specified by User
			5	0.5	2.75				
			6	1.4	3.75				
			7	2.4	4.75				
3/4	3/4 Gold	15 Tons *	4	0.5	1.75	1 1/4 Hex (3/4-10 Thd.)	125	3 1/2	Specified by User
			5	0.5	2.75				
			6	1.4	3.75				
			7	2.4	4.75				
1"	1" Blue	8 1/2 Tons *	4	0.5	1.75	1 5/8 Hex (7/8-9 Thd.)	150	3 1/2	Specified by User
			5	0.5	2.75				
			6	1.4	3.75				
			7	2.4	4.75				
1"	1" Red	10 1/2 Tons *	4	0.5	1.75	1 5/8 Hex (1"- 8 Thd.)	150	3 1/2	Specified by User
			5	0.5	2.75				
			6	1.4	3.75				
			7	2.4	4.75				
1"	1" Gold	18 Tons *	4	0.5	1.75	1 5/8 Hex (7/8-9 Thd.)	150	3 1/2	Specified by User
			5	0.5	2.75				
			6	1.4	3.75				
			7	2.4	4.75				
1"	1" Green	22 Tons *	4	0.5	1.75	1 5/8 Hex (1"- 8 Thd.)	150	3 1/2	Specified by User
			5	0.5	2.75				
			6	1.4	3.75				
			7	2.4	4.75				

* Load capacity of model 71 (with heel) is 60% of that shown above

Toll Free 866-EZSETUP



Power Pallet push/pull die loading system, for up to 6,000 lbs

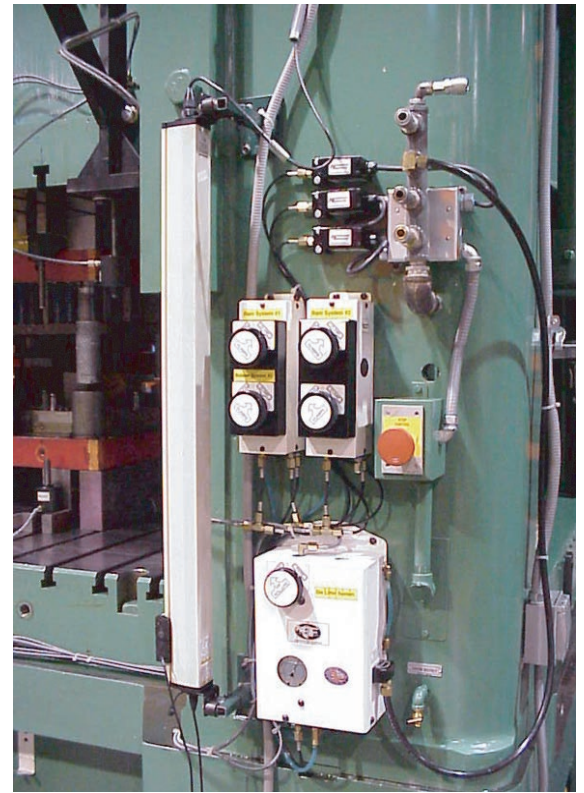

Air-Driven Hydraulic Power Supply with Five-Circuit Controls

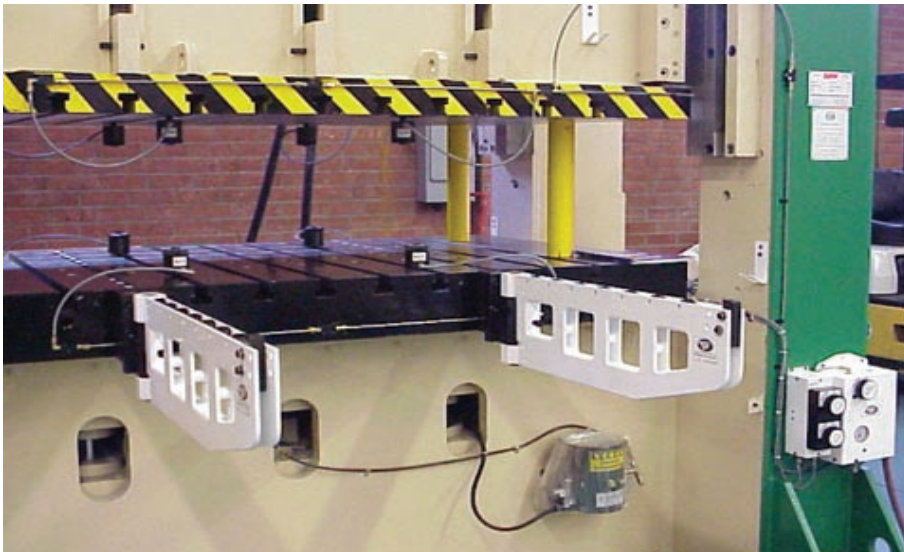

Complete Quick Die Change System

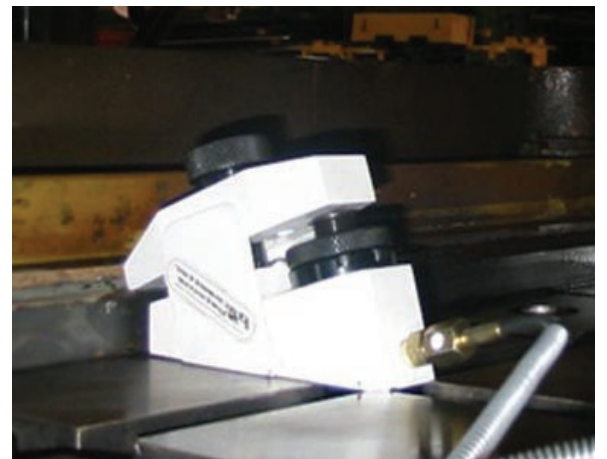

Gorilla Grip Adjustable Hydraulic Rocker Clamp



Bolster Extensions Folded on Press

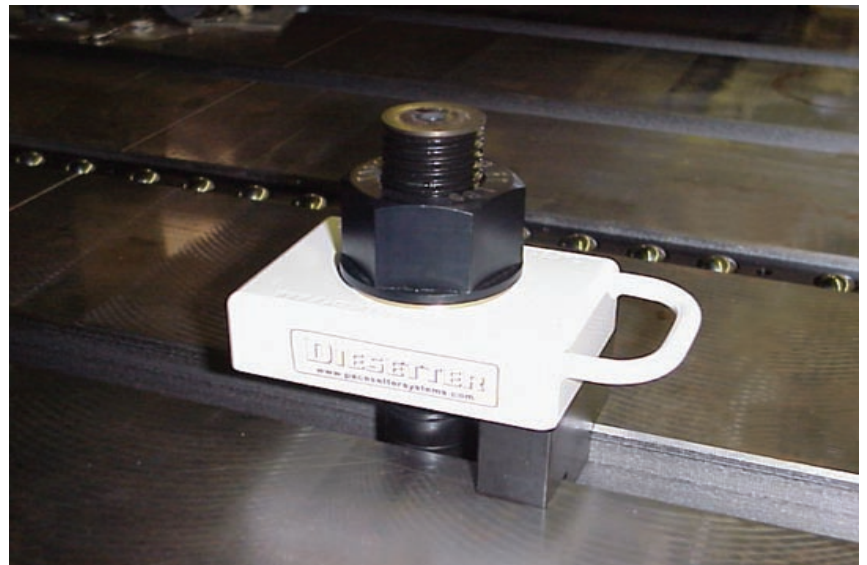

Pacesetter Signature Diesetter Clamps